



atmosfera suggestiva
stile contemporaneo
gusto esotico



INDICE

index / index

- | | | | |
|-------|--|-------|--|
| 6/7 | Canna Africana
cape reed / roseau african | 32/33 | Erba Palustre
marsh Grass / herbe des marais |
| 8/9 | Canna Africana XL
cape reed xl / roseau african xl | 34/35 | Cabina
cabin / cabine |
| 10/11 | St Bali
st bali / st bali | 36/37 | Chioschi Modulari
modular kiosks / kiosques modulaires |
| 12/13 | Esotic
esotic / esotic | 38/41 | Chioschi Modulari - MADE IN ITALY
modular kiosks / kiosques modulaires - MADE IN ITALY |
| 14/15 | Ombrelloni Quadrati
square sun shaders / parasols carres | 42/43 | Chioschi E Chiringuitos
kiosks and chiringuitos / kiosques et chiringuitos |
| 16/17 | Makuti
makuti / makuti | 44/49 | Composizioni
compositions / compositions |
| 18/19 | Alang Alang
alang alang / alang alang | 50/61 | Arredo E Complementi
furniture and accessories / ameublement et decoration |
| 20/21 | Stile Africa
style afrique / african style | 62/63 | Suite Bamboo
bamboo suite / suite bambou |
| 22/23 | Makuti Sintetico
synthetic makuti / synthetique makuti | 64/65 | Gazebo Bamboo
bamboo gazebo / bambou gazebo |
| 24/25 | Canna Africana Mix
cape reed mix / roseau african mixte | 66/67 | Gazebo
gazebo / gazebo |
| 26/27 | Palma Sintetica Gialla
synthetic palm yellow / palm synthetique jaune | 68/71 | Costruzioni
constructions / constructions |
| 28/29 | Palma Sintetica Marrone/Grigio
synthetic palm gray/brown / palm synthetique gris/brune | 72/73 | Dimensioni
dimensions / dimensions |
| 30/31 | Java
java / java | | |

Come nasce un sogno

How is a dream

Comment un rêve

GIO' STEMAR nasce come la realizzazione di un sogno... un sogno nato da un'idea che si trasforma in progetto e diventa realtà. Un Sogno che si fa materia attraverso parametri di qualità.

Realizziamo un prodotto innovativo dando vita al vostro sogno; a un qualcosa di diverso dal solito cercando di rompere ogni schema canonico utilizzando materiali naturali provenienti da tutto il mondo e prodotti tecnologici rispettosi dell'ambiente, ecosostenibilità ed ecocompatibilità realmente applicate!

Progettiamo e arrediamo i vostri spazi con i giusti accorgimenti tecnico/funzionali per renderli vivi, accoglienti e unici utilizzando i migliori prodotti che Madre Natura ci offre.

Dallo stabilimento balneare (di cui siamo promotori), al villaggio turistico, alla piscina dell'albergo, all'agriturismo, al bed & breakfast piuttosto che al giardino di casa, GIO' STEMAR, è in grado di dare quel giusto tocco esotico per fare del tuo spazio un luogo affascinante, confortevole e ospitale.

Progettazione dello spazio ed armonia dei prodotti scelti e studiati su misura, selezione dei materiali, sono i nostri principali servizi che possiamo offrire grazie alla nostra esperienza e al nostro staff di tecnici e architetti in grado di soddisfare ogni desiderio e... sogno.

GIO' STEMAR born as the realization of a dream... a dream born from an idea that turns into a project becomes reality. A dream that becomes matter through quality parameters.

We create an innovative product, creating your DREAM to something different than the usual trying to break any canonical schema using natural materials from around the world and technology products environmentally friendly. Sustainability and environmental compatibility actually applied!

We design and furnish your space with the right precautions technical/functional to make them alive, comfortable and unique products using

the best that Mother Nature has to offer.

At the beach (which we are promoters), to resort, the swimming pool, the farm, the bed and breakfast rather than the backyard, GIO' STEMAR, is able to give the right exotic touch to make your space a strikingly beautiful, comfortable and welcoming.

Design of space and harmony of selected products and tailor-made, material selection, are our main services we can offer our experience and our staff. engineers and architects to meet every desire and... dream.

GIO' STEMAR né comme la réalisation d'un rêve... un rêve né d'une idée qui se transforme en un projet devient réalité. Un rêve qui devient matière à travers les paramètres de qualité.

Nous créons un produit innovant, créer votre rêve de quelque chose de différent que d'habitude en essayant de briser les schémas canoniques utilisant des matériaux naturels de partout dans le monde et des produits technologiques respectueux de l'environnement. Compatibilité durabilité de l'environnement et effectivement appliquée!

Nous concevons et meubler votre espace avec les bonnes précautions techniques / fonctionnelles afin de les rendre vivants, confortable et

unique des produits utilisant le meilleur que Mère Nature a à offrir.

Sur la plage (dont nous sommes les promoteurs), de recourir, la piscine, le parc, le lit et le petit déjeuner plutôt que de l'arrière-cour, GIO' STEMAR, est capable de donner la bonne touche d'exotisme à faire de votre espace un d'une beauté frappante, confortable et accueillant.

Conception de l'espace et l'harmonie de produits sélectionnés et sur mesure, choix des matériaux, sont nos principaux services que nous pouvons offrir notre expérience et de notre personnel ingénieurs et des architectes pour répondre à toutes les envies et... rêve.

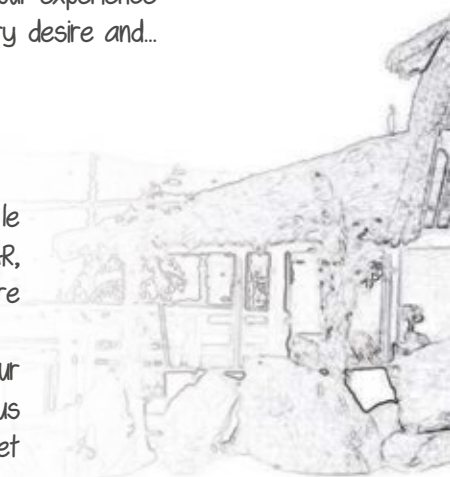





CANNA AFRICANA

CAPE REED

ROSEAU AFRICAN



Coperture di varie dimensioni e forme, realizzate con tegole in canna africana, prodotto naturale ed ecologico proveniente dall'Africa meridionale e complete di clip da fissare su tondini metallici. Materiale ideale in zone ventose, necessita di scarsa manutenzione. Sono disponibili diverse soluzioni, dimensioni, colorazione a scelta del cliente anche con guaina interna per dare alle coperture maggiore resistenza all'acqua.



Hedges of various sizes and shapes, made with tiles cane African natural and ecological product coming from southern and complete with clip for fixing on metal rods. Ideal material in windy areas, requires little maintenance. Different solutions are available, size, color chosen by the customer with inner sheath to give the covers more water resistant.

Haies de différentes tailles et formes, faits de carreaux de canne produit africaine naturel et écologique provenant de clip sud et avec pour la fixation sur des tiges métalliques. Matériau idéal dans les zones venteuses, nécessite peu d'entretien. Différentes solutions sont disponibles, la taille, la couleur choisie par le client avec gaine intérieure pour donner au couvre plus résistant à l'eau.





CANNA AFRICANA "XL"

CAPE REED XL

ROSEAU AFRICAN XL



Coperture di varie dimensioni e forme, realizzate con tegole in canna africana di lunghezza maggiore.

Covers of various sizes and shapes, made with tiles in the barrel African length greater.

Couvertures de tailles et de formes différentes, faites avec des carreaux dans la plus grande longueur du canon africaine.





ST BALI

ST BALI

ST BALI



Coperture rotonde o rettangolari di diverse dimensioni, realizzate intrecciando un filamento d'erba naturale. Di facilissima collocazione sugli ombrelloni: la copertura va semplicemente appoggiata sulla struttura portante, senza necessità di agganci di sorta.

Covers round or rectangular sizes made by braiding a natural grass thread. Very easy to place on sun-shades: the covering can be simply placed on the supporting frame, without any need for fastenings.

Couvertures rondes ou rectangulaires de différentes dimensions, réalisées en tressant filets d'herbe naturelle. Très facile à placer sur les parasols, la couverture va simplement appuyée sur la structure portante, sans qu'il soit nécessaire l'accrocher.





ESOTIC
ESOTIC
ESOTIC



Coperture rotonde disponibili in varie dimensioni, ideali per ombrelloni, laddove si voglia dare un tocco in stile "hawaiano". Sono inoltre disponibili pannelli quadrati, idonei per ogni copertura. Se i pannelli vengono sovrapposti su una considerevole pendenza si migliora il flusso di acqua in caso di pioggia.

Round coverings available in various sizes, ideal for sun umbrellas when a "Hawaiian" style is desired. Square panels are also available, suitable for various roofing purposes. If the panels are stacked on a steep incline improves the flow of water in case of rain.

Couvertures rondes disponibles en plusieurs dimensions, idéales pour parasols qui veulent apporter une touche Hawaïenne. Disponibles aussi en panneaux carrés, idéales pour couvertures en générale. Si les panneaux sont empilés sur une pente raide améliore l'écoulement de l'eau en cas de pluie.





OMBRELLONI QUADRATI
SQUARE SUN SHADERS
PARASOLS CARRÉS



Ombrelloni quadri (cm 200 circa) dalla struttura in metallo e dalla copertura con stecche di bambù legate con filo sintetico. Ideali per dare un tocco fresco ed esotico allo spazio da arredare.

Square sunshades (200 cm square approx) with metal structure and covered by bamboo canes tied with synthetic thread. Ideal to give a cool and exotic touch to the area being furnished.

Parasols carrés (environ cm 200) en structure métallique avec couvertures à baleines de bambou liées avec fil synthétique. Ils sont l'idéal pour donner une touche fraîche et exotique à l'espace à meubler.





MAKUTI
MAKUTI
MAKUTI



Copertura in foglie di palma, disponibili sia in rotoli che in tegole, ideali per la realizzazione di ombrelloni e coperture.

Roof made of palm leaves, available in rolls or tiles, ideal for the construction of roofs and umbrellas.

Toit en feuilles de palmier, disponible en tuiles faisceaux, idéal pour la construction de toits et de parapluies.

ALANG ALANG

ALANG ALANG

ALANG ALANG



Rotolo di erba naturale essiccata rilegata su corda.

Rouleau d'herbe naturelle séchée reliée sur corde.

Rope-bound dried grass roll.





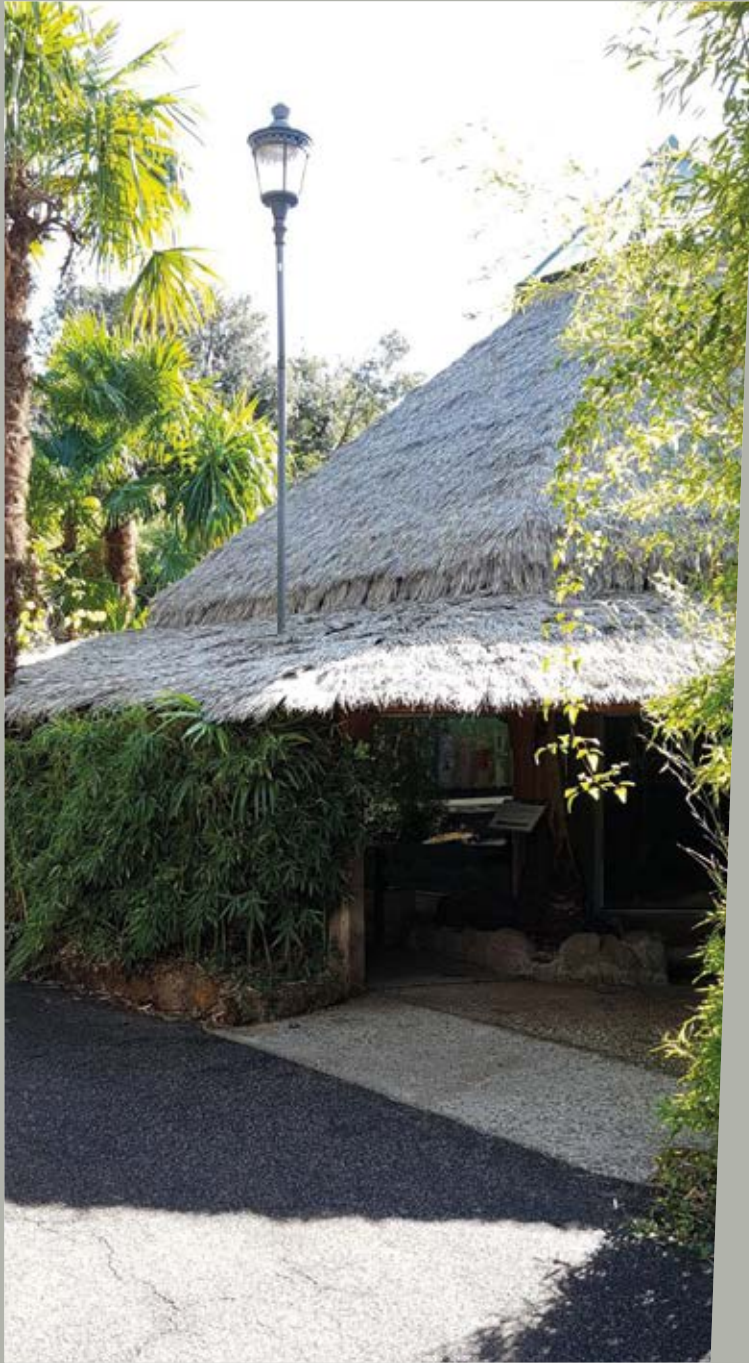

Tegola sintetica da fissare su perlinati; perfetta imitazione delle classiche coperture in paglia palustre.

Tuile synthétique à fixer sur des planches en bois; parfaite imitation des toitures en chaume.

Synthetic roof tile for panelling; exact replica of traditional thatched coverings.

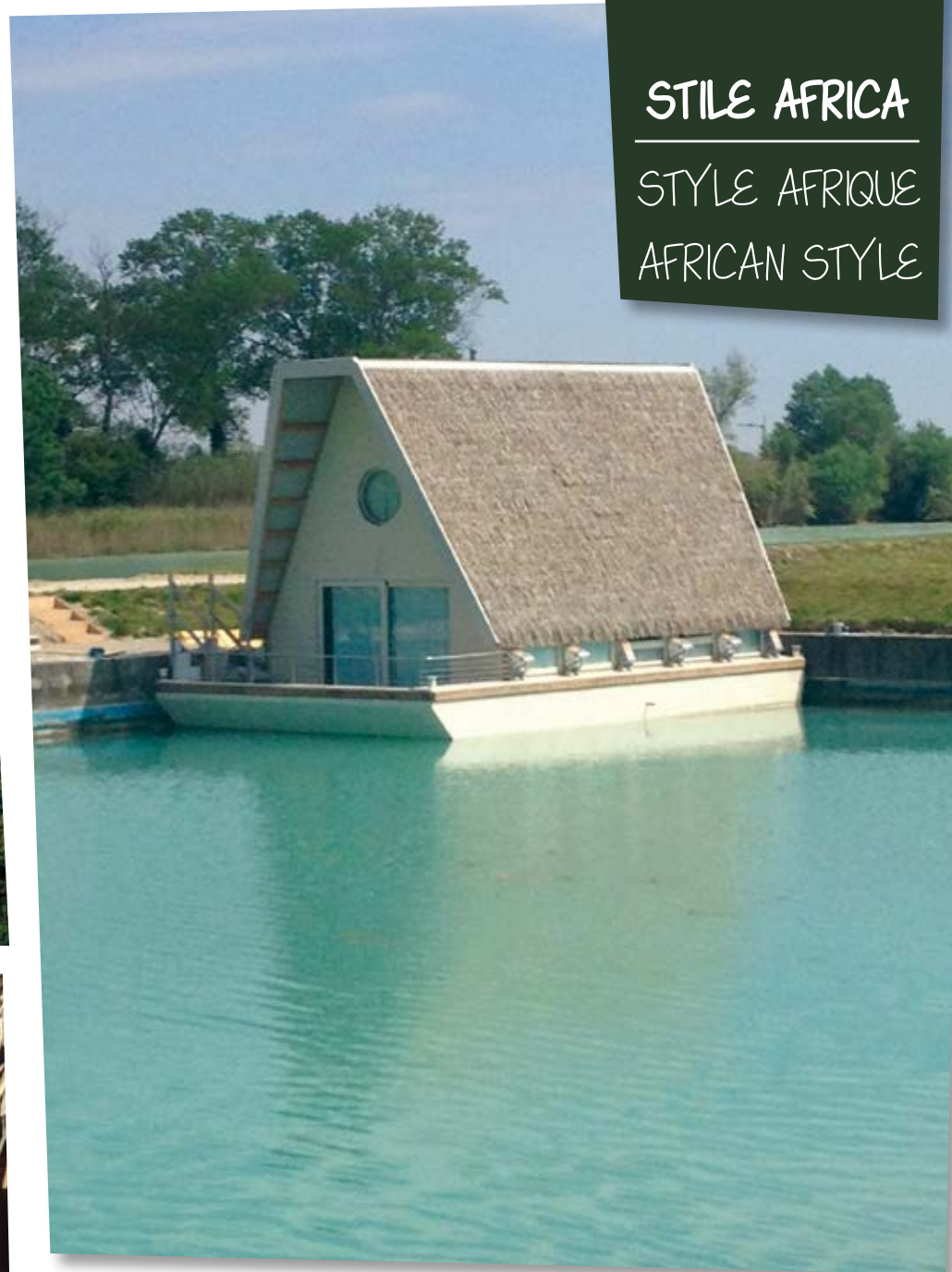

STILE AFRICA

STYLE AFRIQUE

AFRICAN STYLE

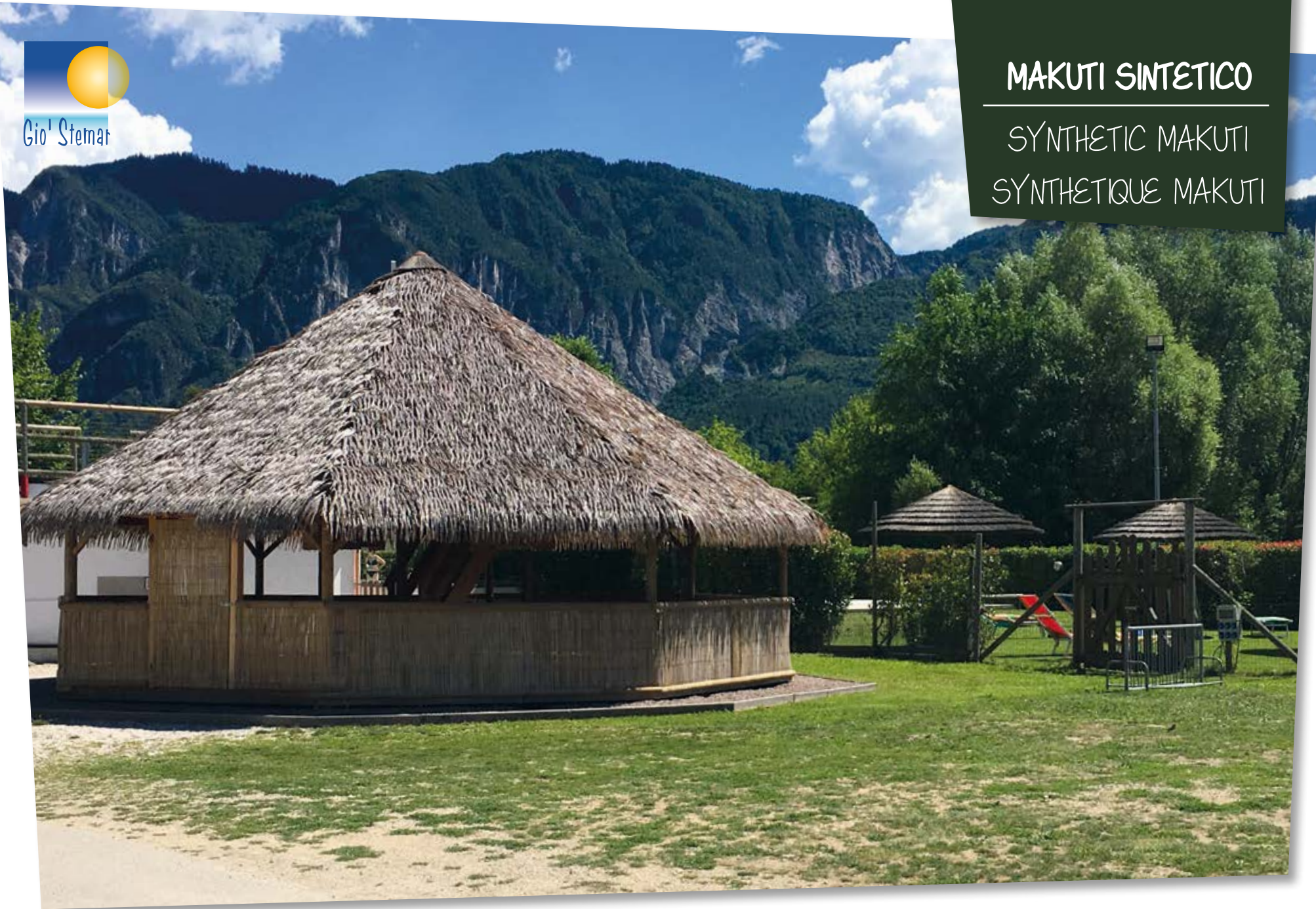

MAKUTI SINTETICO

SYNTHETIC MAKUTI

SYNTHETIQUE MAKUTI



Coperture impermeabili, resistenti agli agenti atmosferici. La loro durata e garanzia è superiore a quella dei prodotti naturali.

Waterproof covering, resistant to atmospheric agents. The advantages: less wear and more resistance than natural fiber coverings.

Couverture imperméable, résistante aux agents atmosphériques. Sa durée et garantie est supérieure à celle la des produits naturels.



CANNA AFRICANA MIX

CAPE REED MIX

ROSEAU AFRICAN MIXTE



Non necessita di manutenzione, viene impiegata soprattutto su costruzioni definitive, ha l'aspetto della tradizionale canna africana ma la durata è superiore. Può essere applicata sia con le classiche clips su tondini diam. 8 mm o fissata direttamente tramite viti / chiodi.



Requires no maintenance, is used mainly on construction definitive, has the look of traditional African cane but the duration is higher. Can be applied either with the classic clips of rods diam. 8 mm or attached directly with screws nails.



Ne nécessite aucun entretien, est principalement utilisé pour la construction définitive, a l'apparence de la canne traditionnelle africaine, mais la durée est plus élevée. Peut être appliqué soit avec les clips classiques de diam tiges. 8 mm ou fixés directement par l'intermédiaire des vis / clous.





PALMA SINTETICA GIALLA

SYNTHETIC PALM YELLOW

PALM SYNTHETIQUE JANUE



Tegole foglie di palma sintetiche (gialle), dotata di clips per il fissaggio con l'aspetto naturale di foglie.

Synthetic palm tile (yellow), with clips for fixing, with the natural appearance of the leaves.

Carrelage palm synthétique tile (jaune), munni d'agrafes de fixation, avec l'aspect naturel des feuilles.



PALMA SINTETICA MARRONE/GRIGIO

SYNTHETIC PALM GRAY/BROWN

PALM SYNTHETIQUE GRIS/BRUNE



Tegole foglie di palma sintetiche (marrone / grigio), dotata di clips per il fissaggio con l'aspetto naturale di foglie.

Synthetic palm tile (gray / brown), with clips for fixing, with the natural appearance of the leaves.

Carrelange palm synthétique tile (gris / brun), munni d'agrafes de fixation, avec l'aspect naturel des feuilles.





JAVA
JAVA
JAVA





Tegola Java in materiale sintetico, dotata di clips per il fissaggio, con l'aspetto naturale di foglie. Disponibile anche una versione dallo spessore ridotto ideale per rivestimento coperture costruzioni.

Javan plastic tile with clips for fixing, with the natural appearance of the leaves. Also available in a version by the reduced thickness is ideal for construction roofing coating.

Carrelage Giava en matière synthétique, muni d'agrafes de fixation, avec l'aspect naturel des feuilles. Il ya aussi une version réduite épaisseur idéale pour la construction de toiture revêtement.



ERBA PALUSTRE

ERBA PALUSTRE

ERBA PALUSTRE





CABINA

CABINA

CABINA







CHIOSCHI MODULARI

MODULAR KIOSKS
KIOSQUES MODULAIRES



Chioschi/chiringuitos realizzati con dei moduli preallestiti di eucalipto, bamboo e legno. Si possono realizzare misure a scelta adattabili alle nostre coperture standard.

Kiosks/chiringuitos made of prefabricated modules of eucalyptus, bamboo and wood. You can achieve sizes adaptable to our standard covers.



Kiosques/chiringuitos en modules préfabriqués d'eucalyptus, bamboo et de bois. Vous pouvez obtenir des tailles adaptables à nos couvertures standards.

CHIOSCHI MODULARI

MODULAR KIOSKS

KIOSQUES MODULAIRES

 MADE IN ITALY



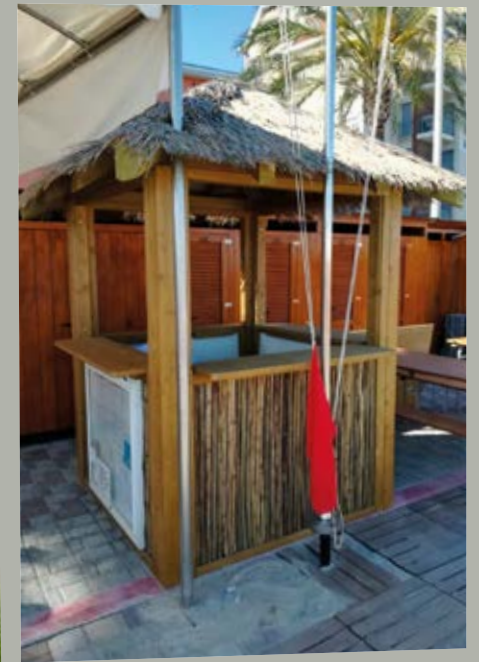







CHIOSCHI E CHRINGUITOS

KIOSKS AND CHRINGUITOS

KIOSQUES ET CHRINGUITOS



Chioschi-bar realizzabili con materiali e prodotti diversi. Si possono personalizzare in base alle esigenze del cliente, dalla copertura al rivestimento interno, alle chiusure serali.

Bar-kiosks can be built in different materials. They can be customized to customer's requirements, from covering to inside lining, closures evening.

Kiosques-bar réalisables avec matériaux et produits différents. Ils peuvent être personnalisés selon les exigences du client, de la couverture au revêtement interne, soirée fermetures.

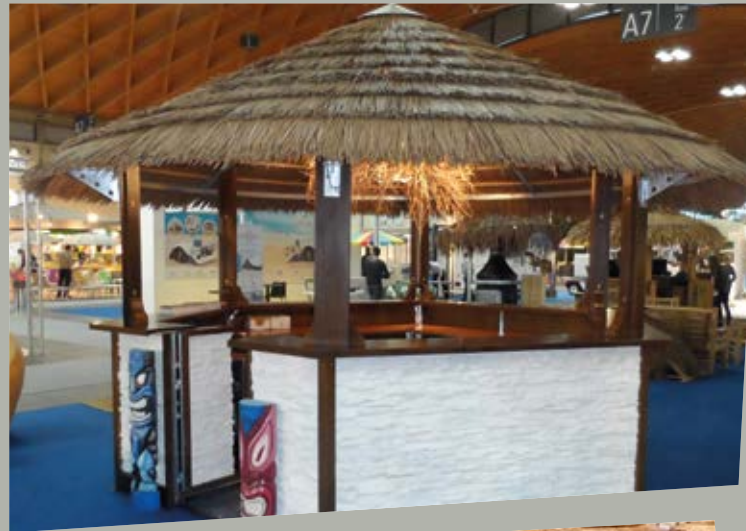



COMPOSIZIONI
COMPOSITIONS
COMPOSITIONS



Composizioni realizzate con utilizzo di diverse tipologie di prodotti: dal tavolo (rotondo, quadrato, triangolare o rettangolare) alle docce, etc, personalizzabili con qualsiasi tipologia di copertura.

Compositions made by using various kinds of products: from tables (round, square, triangular or rectangular) to showers, etc customizable with any kind of coverings.

Compositions réalisées en utilisant différentes typologies de produits: du table (ronde, carré ou rectangulaire) aux douches, etc, qui peuvent être personnalisés avec quelque soit typologie de couverture.













ARREDO E COMPLEMENTI

FURNITURE AND ACCESSORIES
AMEUBLEMENT ET DECORATION



Salotti, tavoli, sedie e sgabelli realizzati con i più svariati materiali naturali, provenienti da tutto il mondo. Accessori per impreziosire interni ed esterni, dai lampadari in conchiglia alle staccionate in eucalipto o in bambù, fino ai lampioni in canna africana.

Living room suites, tables, chairs and stools made of the most diverse natural materials, imported from all over the world. Accessories to embellish both inside and outside areas, from shell lampshades to Eucalyptus or Bamboo fences, right up to lamp shades in African Reed.

Compositions réalisées en utilisant différentes typologies de produits: du table (ronde, carré ou rectangulaire) aux douches, etc, qui peuvent être personnalisés avec quelque soit typologie de couverture.









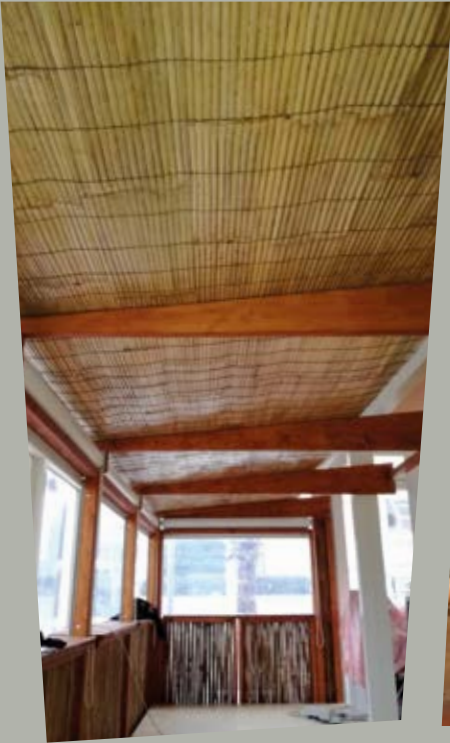















SUITE BAMBOO

BAMBOO SUITE

SUITE BAMBOU



Un angolo realizzato in bamboo dove trascorrere piacevolmente del tempo... la struttura viene consegnata completa di panche e tavolo.

Corner made of bamboo to spend time pleasantly... the structure is delivered complete with benches and tables.

Un angle en bambou pour passer le temps agréablement... la structure est livrée complet avec bancs et table.





GAZEBO BAMBOO

BAMBOO GAZEBO

BAMBOU GAZEBO



Gazebo in bamboo di facile assemblaggio, dotato di tende. Idoneo per creare un angolo d'ombra in spiaggia, in piscina, in un angolo del giardino. All'interno si possono adattare diverse soluzioni: dalla collocazione di lettini, al salottino.

Gazebo bamboo easy assembly, equipped with tents. Suitable to create an angle of shade on the beach, by the pool, in a corner of the garden. Inside you can adapt different solutions: the location of beds in living room.

Gazebo en bambou facile à monter, avec des rideaux. Convient pour la création d'un coin d'ombre sur la plage, de la piscine, dans un coin du jardin. A l'intérieur, vous pouvez adapter des solutions différentes: à partir de l'emplacement des lits dans le salon.





Gio Stemar



GAZEBO
GAZEBO
GAZEBO

Coperture di dimensioni varie; possono essere realizzate in alluminio, in legno, in bamboo o altri materiali. Rifiniti con tende in materiale impermeabile e lavabile.

Covers of various sizes; may be made of aluminum, wood, bamboo or other materials. Finished with curtains of waterproof and washable.

Couvertures de diverses tailles, peut être en aluminium, en bois, en bambou ou en d'autres matériaux.

Fini avec des rideaux de imperméable et lavable.





COSTRUZIONI

CONSTRUCTIONS

CONSTRUCTIONS



Dall'idea al prodotto finito: realizziamo i sogni esotici dei nostri clienti.

From the idea to final product: we make our customer's exotic dreams come true.

A partir de l'idée au produit fini: Nous allons réaliser les rêves exotiques des nos clients.

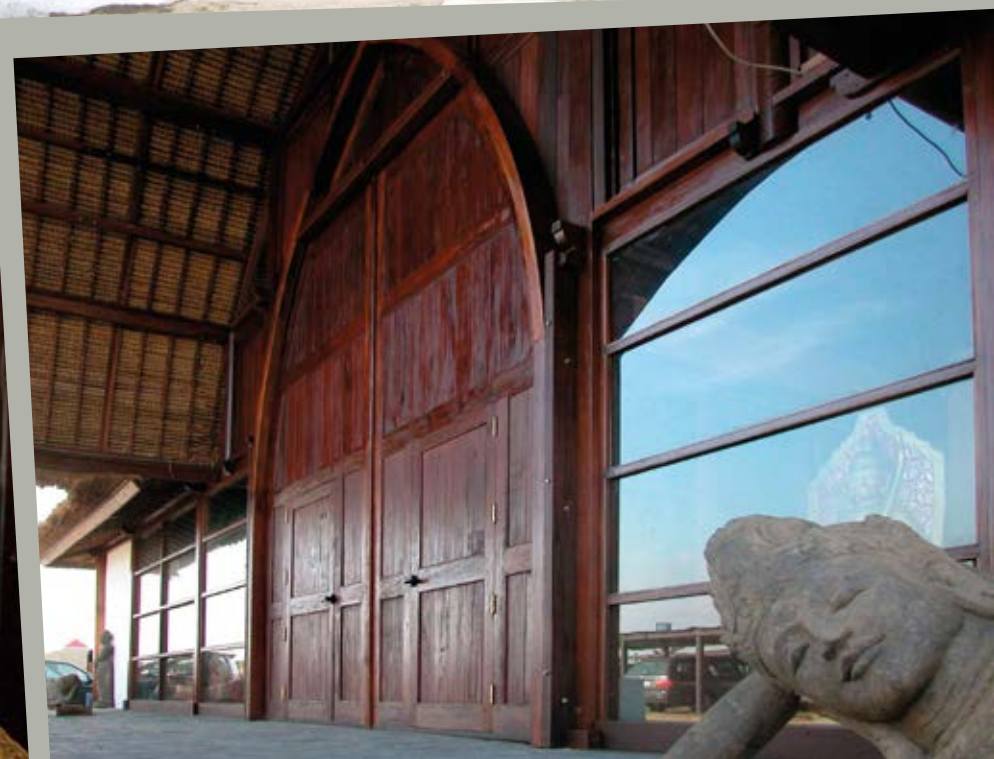





COPERTURE TONDE



200 cm



230 cm



250 cm



280 cm

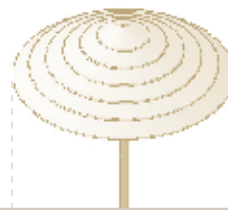

330 cm

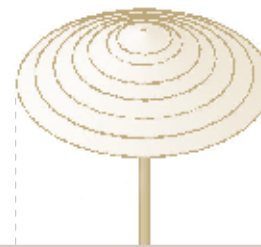

380 cm

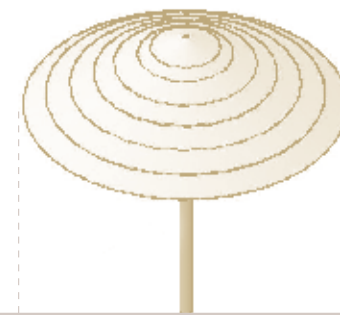

500 cm

COPERTURE OVALI



380 X 230 cm



400 X 280 cm



450 X 280 cm

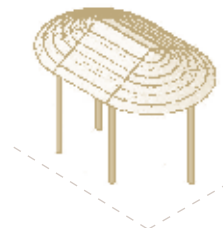

500 X 330 cm

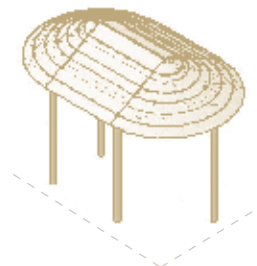

600 X 380 cm

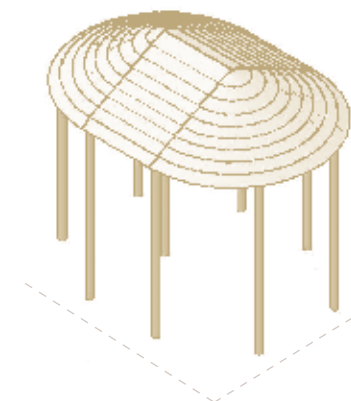

700 X 500 cm

CHIOSCHI E CHRINGUITOS

COMP201

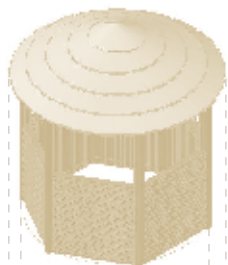

192 cm

330 cm

CIR004

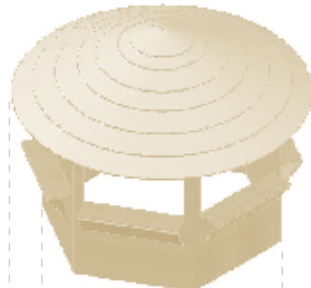

260 cm

380 cm

CIR027

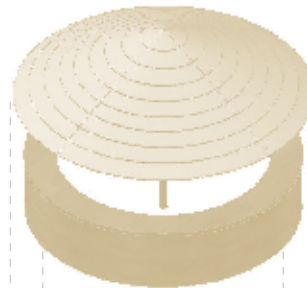

250 cm

380 cm

CIR005

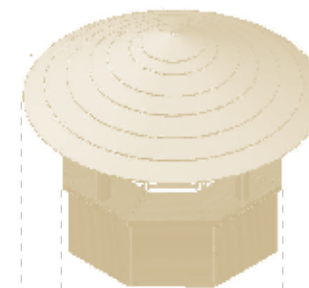

275 cm

380 cm

COMP203

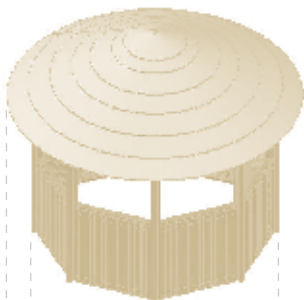

245 cm

380 cm

CIR028

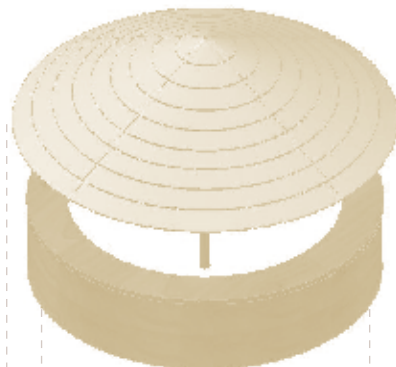

344 cm

500 cm

CIR002

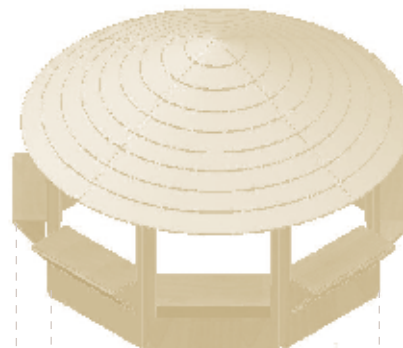

400 cm

500 cm

CIR008

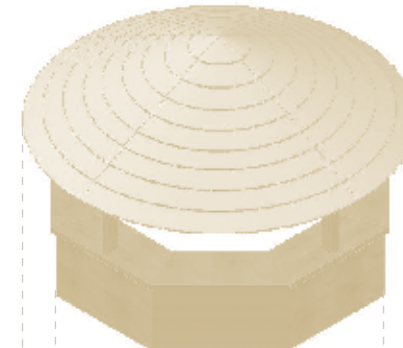

420 cm

500 cm

I disegni e le misure riportate in queste pagine sono solo alcuni esempi di prodotti da noi realizzati.

www.giostemar.it





Tel. +39 0424 382821 - Fax +39 0424 391939
Mobile +39 348 7303424 - +39 348 7303418
info@giostemar.it - www.giostemar.it